

LINEA CONTROL

T90cn-2,5

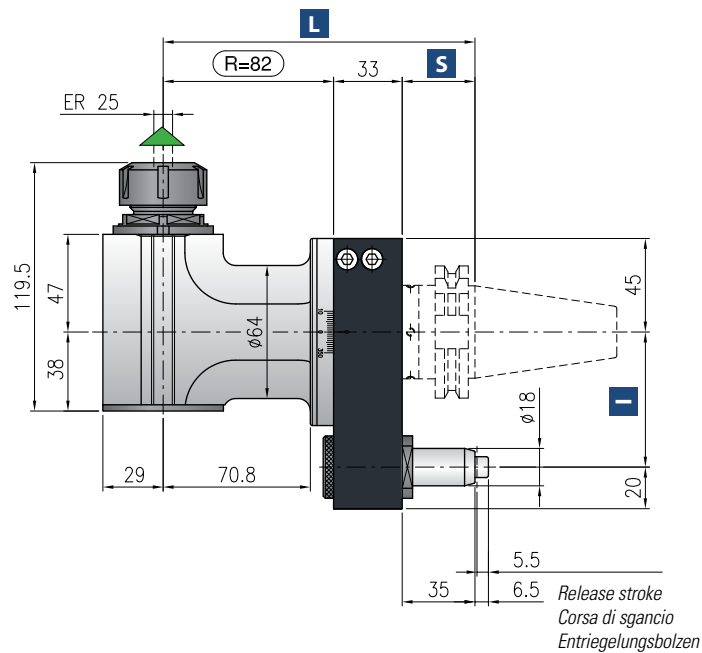

Minimum diameter without tool
 Diametro minimo senza utensile
 Durchmesser min. ohne Werkzeug

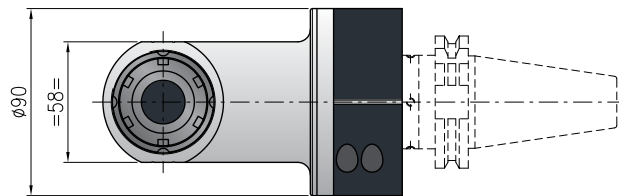
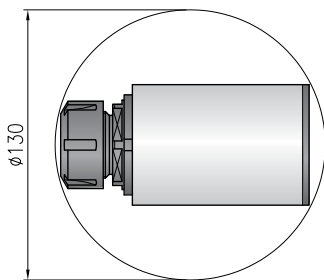

- Ratio
Rapporto / Verhältnis
1:1
- RPM
Velocità / Drehzahl max.
6.000 min⁻¹
- Max. axial load
Max. carico assiale / Max. Axialbelastung
510 N
- Torque
Momento torcente / Drehmoment
30 Nm
- Weight
Peso / Gewicht
5,4 kg
- Collet
Pinza / Spannzange
ER-25 Ø 1/16 mm

*** STANDARD EQUIPMENT INCLUDES:**

- Special bag - wrenches - Grease tube - Instruction book
- Bauletto - Ghiera ER chiavi di servizio - Tubetto di grasso - Libro istruzioni
- Spezialtasche - Schraubenschlüssel - Tube mit Fett - Bedienungsanleitung

Direction of rotation same as machine spindle / senso di rotazione uguale al mandrino / Drehrichtung gleich wie Antriebsspindel



Shank/Cono/Aufnahme	DIN-69871	CAT	MAS-BT	HSK	CAPTO	KM
Size/Grandezza/Größe	40	50	40	63-80	100	63
I	65-80	80-(110*)	65-80-(110*)	65-80-(110*)	80-(110*)	65-80-(110*)
S	35	35	35	42	38	40
L	150	150	150	157	160	155

*optional

Non interchangeable input drive shank/ Coni di attacco non intercambiabili/ Nicht wechselbare Aufnahme

Option / Opzione / Option



bar max
12

Coolant through pin
 Refrigerante attraverso il perno
 Kühlmittelzufuhr durch Bolzen



bar max
12

Coolant through pin and spindle
 Refrigerante interno attraverso utensile
 Kühlmittelzufuhr durch Bolzen und Spindel



min⁻¹
8.000

High speed RPM max.
 Alta velocità RPM max.
 Drehzahl max.



Ø mm
16

Arbor output
 Porta fresa
 Fräseaufnahme



Ø mm max.
16

Weldon output
 Weldon
 Weldon-Aufnahme



HSK-32

Quick Change
 Attacco rapido
 Schnellwechsellaufnahme



ER-25/ER-16

Double output
 Doppia uscita
 Doppelter Ausgang