

LINEA CONTROL

T90cn-0,5C

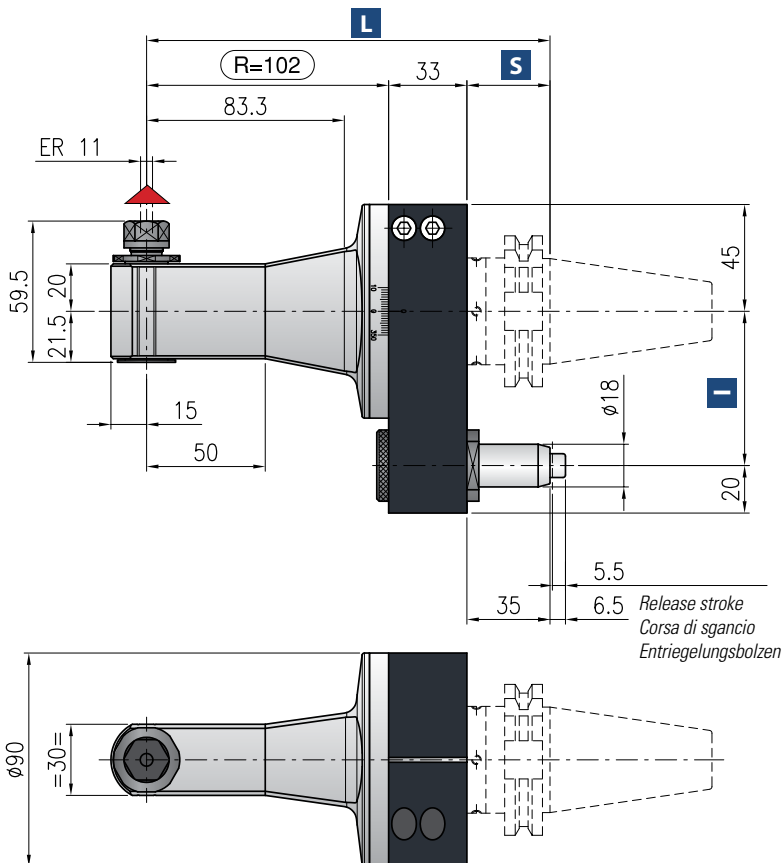

Minimum diameter without tool
 Diametro minimo senza utensile
 Durchmesser min. ohne Werkzeug

- Ratio
Rapporto / Verhältnis
1:1
- RPM
Velocità / Drehzahl max.
10.000 min⁻¹
- Max. axial load
Max. carico assiale / Max. Axialbelastung
120 N
- Torque
Momento torcente / Drehmoment
8 Nm
- Weight
Peso / Gewicht
4 kg
- Collet
Pinza / Spannzange
ER-11 \varnothing 0,5/7 mm

*** STANDARD EQUIPMENT INCLUDES:**

- Special bag - wrenches - Grease tube - Instruction book
- Bauletto - Ghiera ER chiavi di servizio - Tubetto di grasso - Libro istruzioni
- Spezialtasche - Schraubenschlüssel - Tube mit Fett - Bedienungsanleitung

Direction of rotation opposite to machine spindle / senso di rotazione contrario al mandrino / Drehrichtung entgegen Antriebsspindel

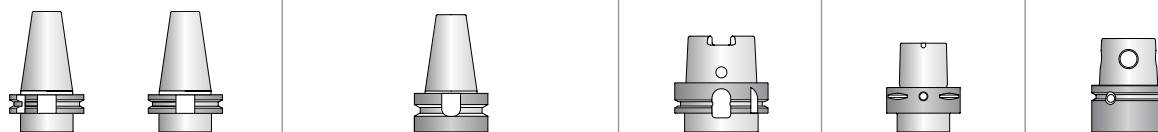

Shank/Cono/Aufnahme	DIN-69871		CAT		MAS-BT		HSK		CAPTO		KM
Size/Grandezza/Größe	30	40	50	30	40	50	63-80	100	C5-C6	C8	50-63
I	65-80	65-80-(110*)	80-(110*)	65-80	65-80-(110*)	80-(110*)	65-80-(110*)	80-(110*)	65-80-(110*)	80-(110*)	65-80-(110*)
S	35	35	35	30	35	41	42	45	38	40	40
L	170	170	170	165	170	176	177	180	173	175	175

*optional

Non interchangeable input drive shank/ Coni di attacco non intercambiabili/ Nicht wechselbare Aufnahme

Option / Opzione / Option



bar max
12

Coolant through pin
 Adduzione refrigerante attraverso il pemo
 Kühlmittelzufuhr durch Bolzen



\varnothing mm max.
6

Weldon output
 Weldon
 Weldon-Aufnahme