

T90-3,5

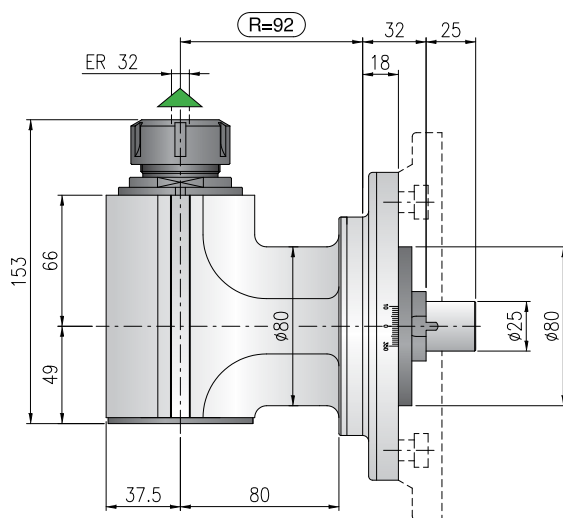

Minimum diameter without tool
 Diametro minimo senza utensile
 Durchmesser min. ohne Werkzeug

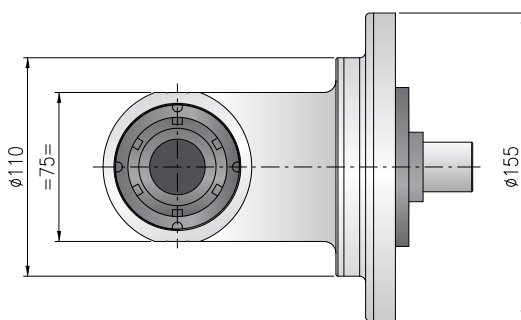
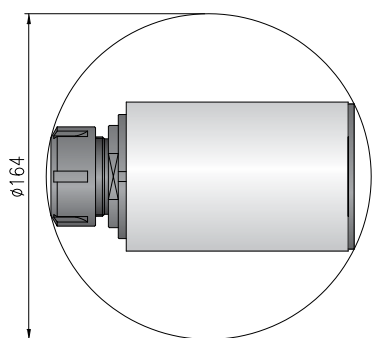

- Ratio
Rapporto / Verhältnis
1:1
- RPM
Velocità / Drehzahl max.
4.000 min⁻¹
- Max. axial load
Max. carico assiale / Max. Axialbelastung
1.250 N
- Torque
Momento torcente / Drehmoment
50 Nm
- Weight
Peso / Gewicht
11 kg
- Collet
Pinza / Spannzange
ER-32 ø 2/20 mm

*** STANDARD EQUIPMENT INCLUDES:**

- Special bag - wrenches - Grease tube - Instruction book
- Bauletto - Ghiera ER chiavi di servizio - Tubetto di grasso - Libro istruzioni
- Spezialtasche - Schraubenschlüssel - Tube mit Fett - Bedienungsanleitung

Direction of rotation same as machine spindle / *sensò di rotazione uguale al mandrino / Drehrichtung gleich wie Antriebsspindel*

Shank/Cono/Aufnahme						
	DIN-69871	CAT	MAS-BT	HSK	CAPTO	KM

Option / Opzione / Option

bar max 12	min ⁻¹ 6.000	Ø mm 27	Ø mm max. 20	ISO-30 HSK-40	ER-32/ER-20
Coolant through spindle Adduzione refrigerante interna Kühlmittelzufuhr durch Spindel	High speed optional RPM max. Opzione alta velocità RPM max. Drehzahl max.	Arbor output Porta fresa Fräseraufnahme	Welding output Welding Welding-Aufnahme	Quick Change Attacco rapido Schnellwechsellafnahme	Double output Doppia uscita Doppelter Ausgang